

REVISIONS				
ZONE	REV.	DESCRIPTION	DATE	APPROVED
	1	Drawing Created	1/13/2021	

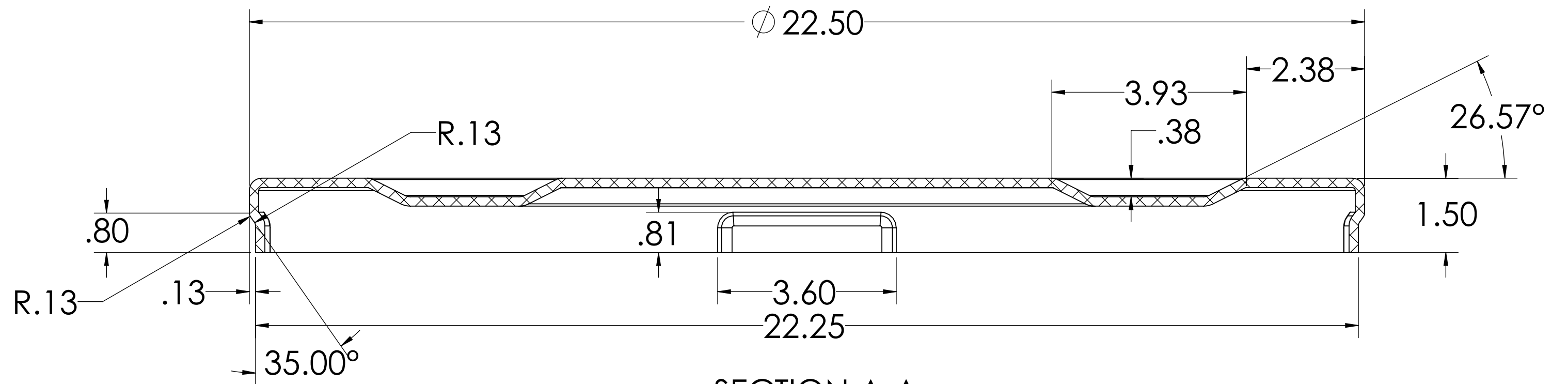
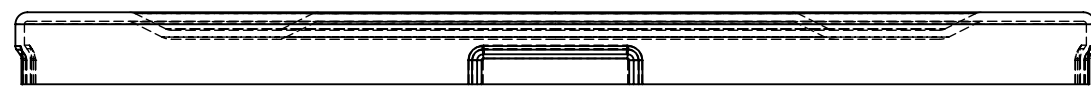
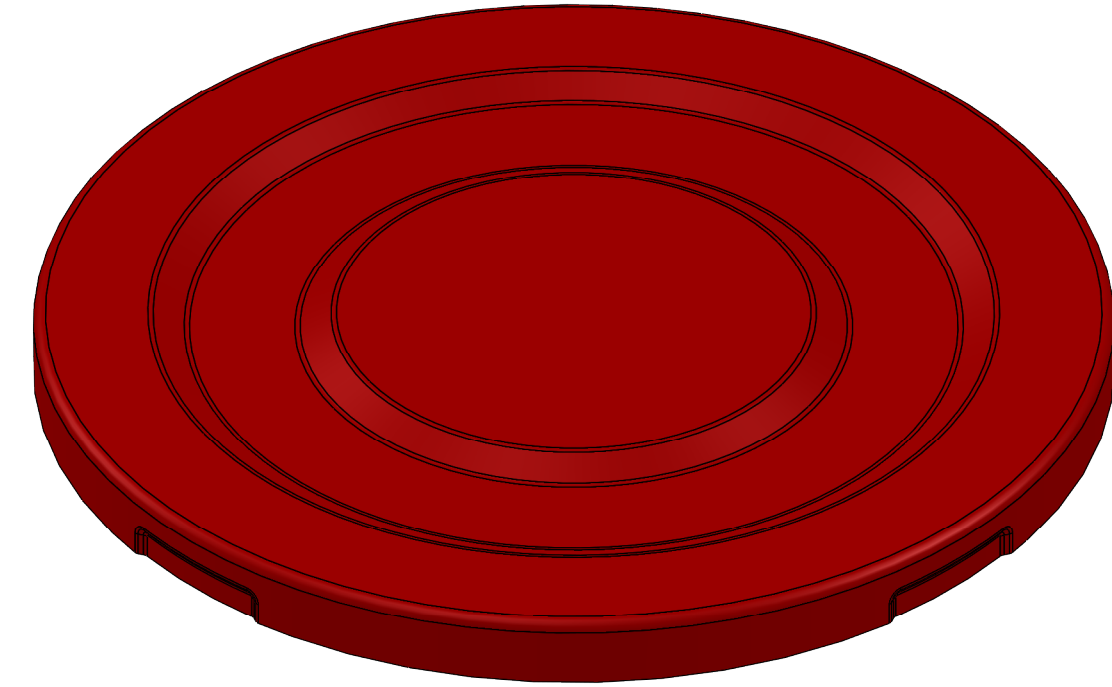
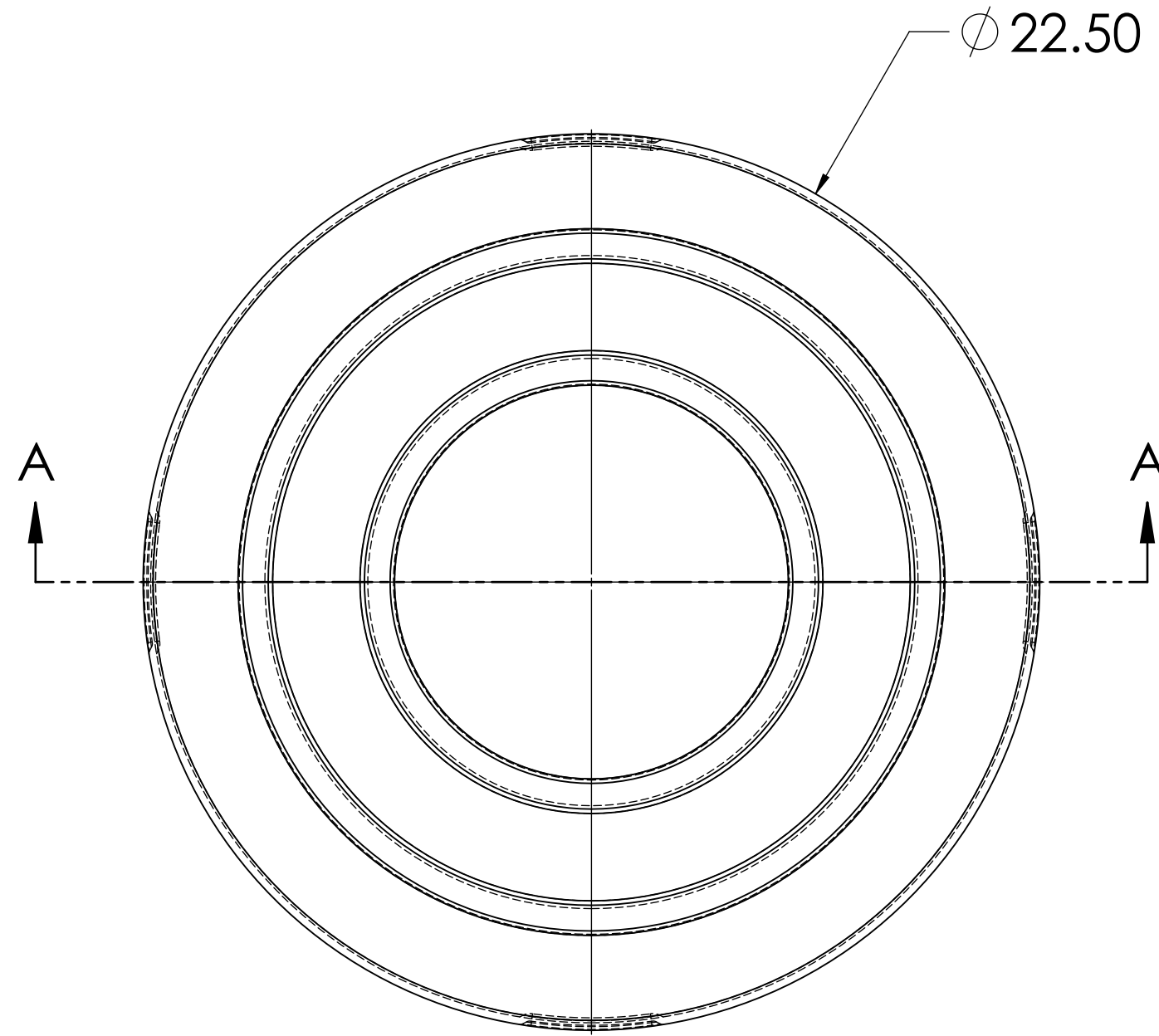

SECTION A-A
SCALE 1 : 2

PROPRIETARY AND CONFIDENTIAL
THE INFORMATION CONTAINED IN THIS DRAWING IS THE SOLE PROPERTY OF REMCON PLASTICS, INC. ANY REPRODUCTION IN PART OR AS A WHOLE WITHOUT THE WRITTEN PERMISSION OF REMCON PLASTICS, INC IS PROHIBITED.

UNLESS OTHERWISE SPECIFIED:
DIMENSIONS ARE IN INCHES
TOLERANCES:
DECIMAL +/-0.010 IN/IN
FRACTIONS N/A
ANGLES +/-1°

MATERIAL
FINISH
DO NOT SCALE DRAWING

NAME
DATE
DRAWN BY: BRS 1/13/2021
APPROVED BY:

TITLE:
NDH Drum Lid
WEIGHT:
SCALE 1:4

REMCON 208 Chestnut Street
PLASTICS, INCORPORATED Reading Pa, 19602
DWG. NO. 010201044001XXX
SIZE C SHEET 1 OF 1 REV