

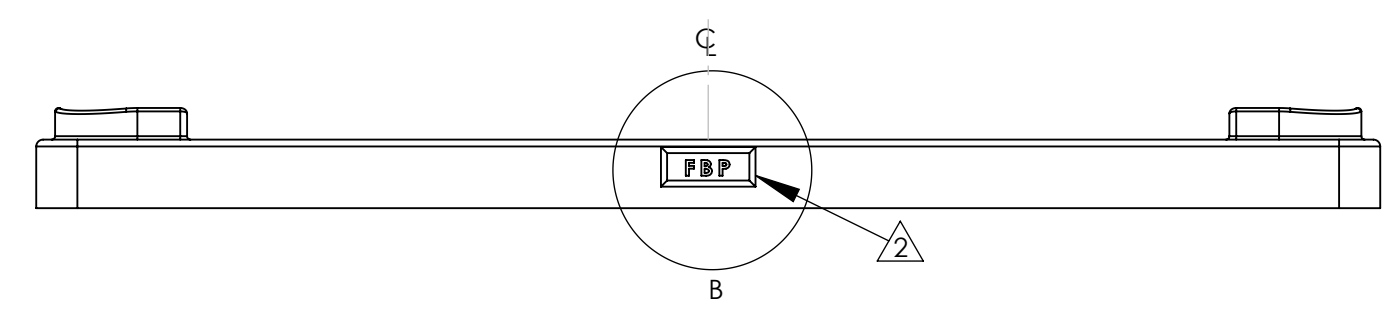

REVISIONS				
ECN	REV.	DESCRIPTION	DATE	APPROVED
	1			
	2	Added FBP Stamp to side on Part	12/4/2017	

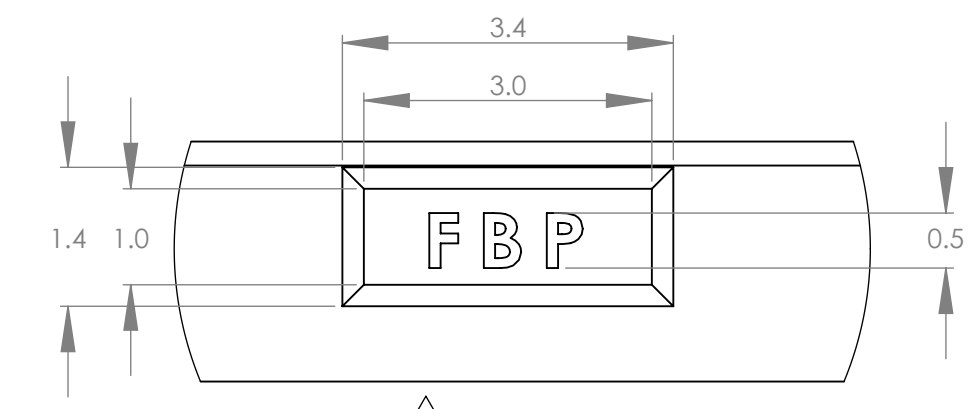
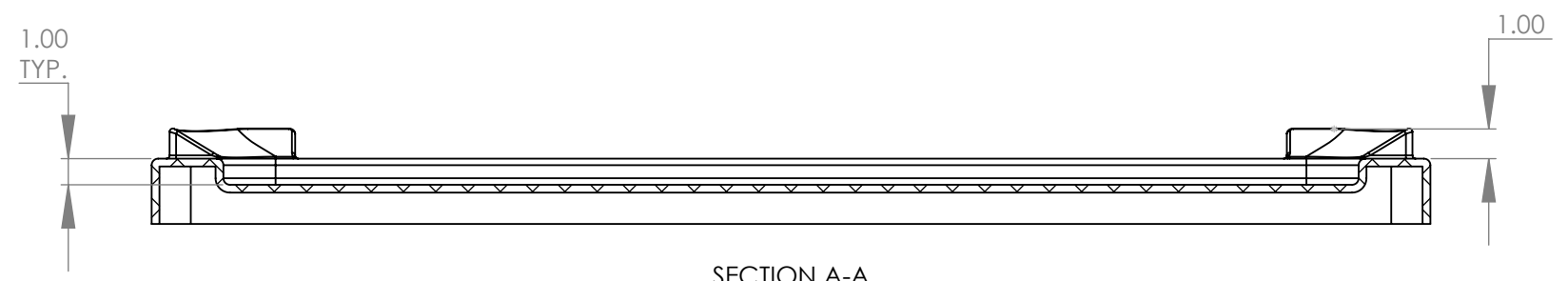
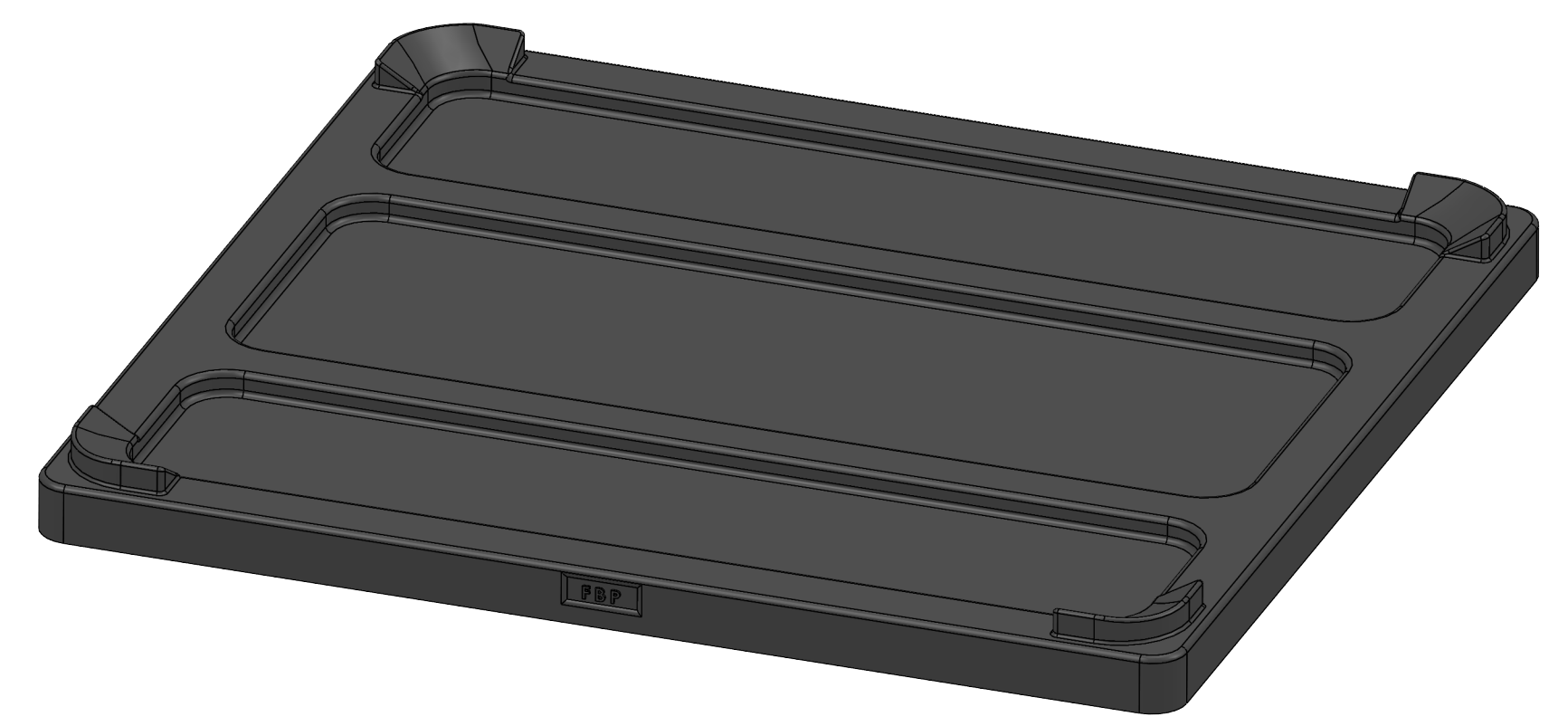
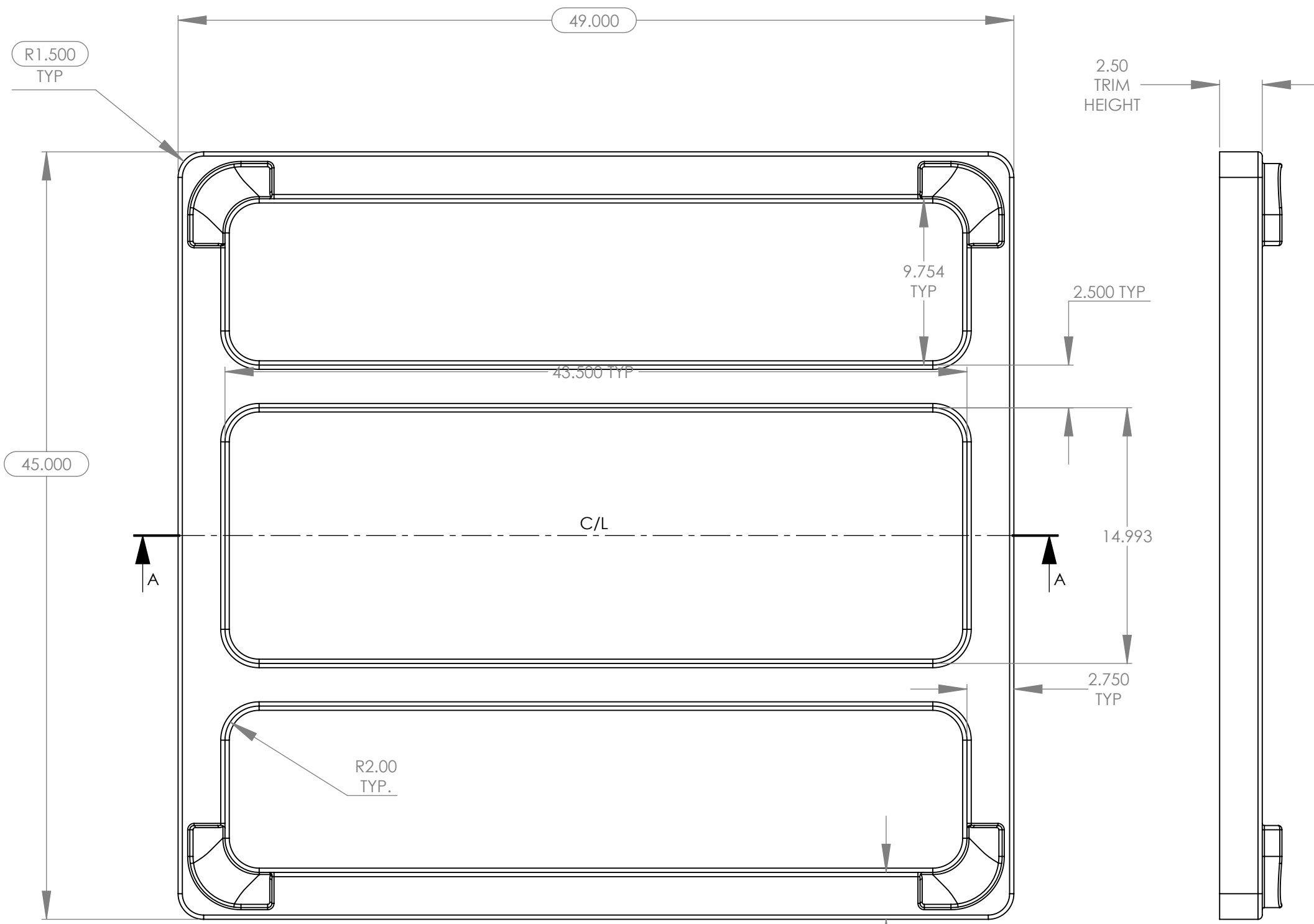

- NOTES:
1. DRAWING SHOWS FINISHED MOLDED PART - TRIMMED
 2. ALL DIMENSIONS ARE TO THEORETICAL SHARP CORNERS
 3. NOMINAL WALL THICKNESS 0.25 INCH
 4. ALL CORNERS AND EDGES HAVE RADII
 5. "XXX" FOR END OF PART NUMBER DENOTES COLOR CODE
 6. REFER TO PART GEOMETRY FOR DIMENSIONS NOT SHOWN
 7. CORRESPONDING BIN DETAILS PROVIDED ON SEPARATE DRAWINGS

COMMENTS: - PROPRIETARY AND CONFIDENTIAL THE INFORMATION CONTAINED IN THIS DRAWING IS THE SOLE PROPERTY OF REMCON PLASTICS, INC. ANY REPRODUCTION IN PART OR AS A WHOLE WITHOUT THE WRITTEN PERMISSION OF REMCON PLASTICS, INC IS PROHIBITED. Address: Remcon Plastics Inc. 208 Chestnut Street, Reading Pa. 19602	PROJECT # -	MATERIAL	TITLE:	 DWG. NO. 010203000001XXX SIZE C SHEET 1 OF 1 REV 2
	UNLESS OTHERWISE SPECIFIED:	FINISH	FBP LID	
	DIMENSIONS ARE IN INCHES TOLERANCES: FRACTIONAL $\pm 1/64$ ANGULAR: $\pm 1/2$ DEG TWO PLACE DECIMAL $\pm .01$ THREE PLACE DECIMAL $\pm .005$ DO NOT SCALE DRAWING	DRAWN BY: toms DATE: 05/06/2020 APPROVED BY:		