

8 7 6 5 4 3 2 1

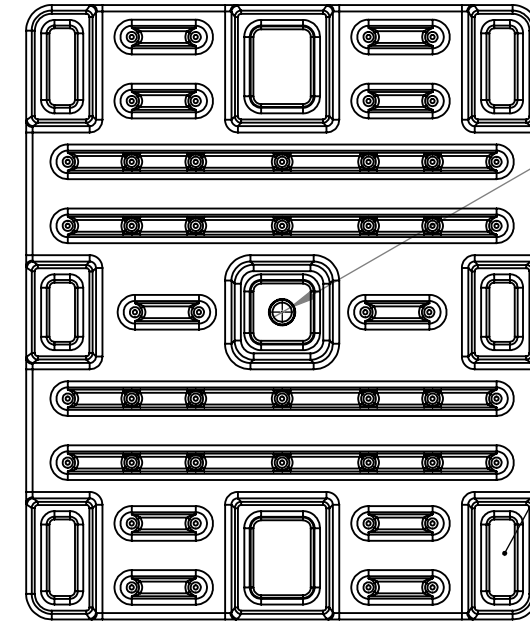
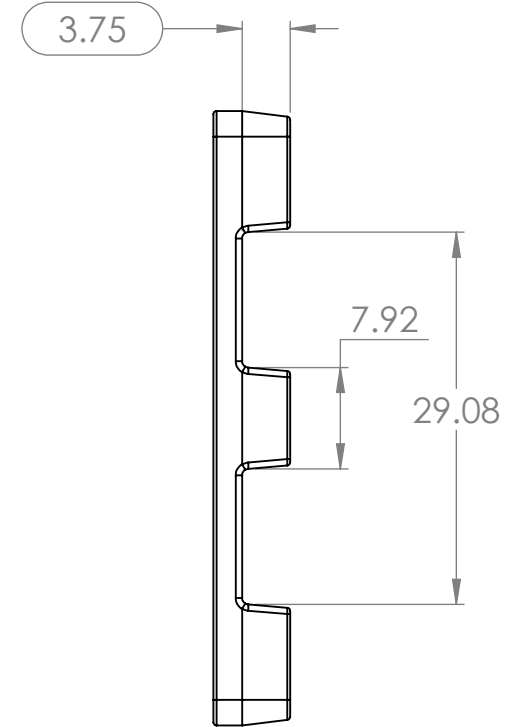
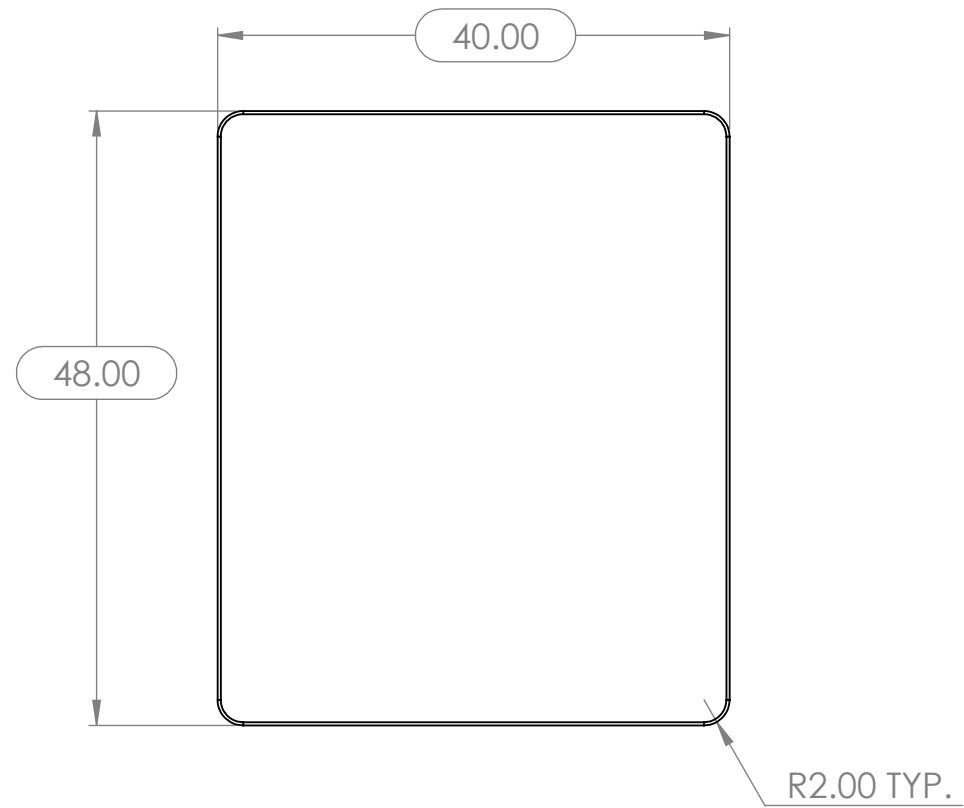
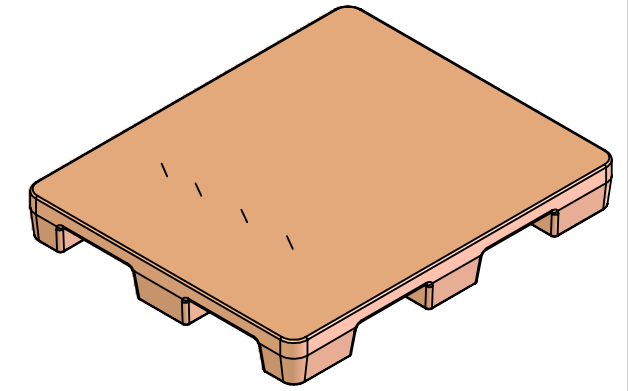

1.00 VENT LOCATION SEE NOTE 9

REMOVABLE FILL PORT

D
C
B
A

D
C
B
A

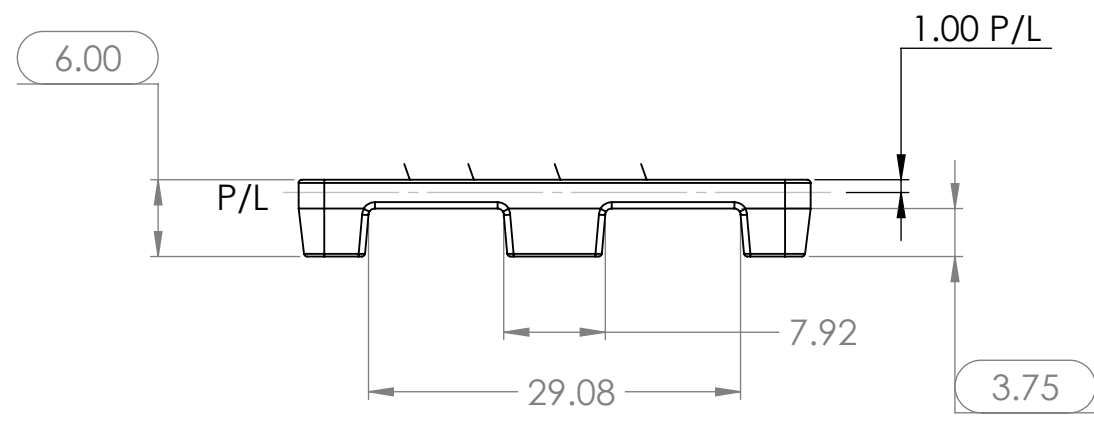

- FEATURES:**
1. ROTOMOLDED POLYETHYLENE CONSTRUCTION
 2. FLAT TOP DECK
 3. FOUR WAY FORK ENTRY
 4. FDA COMPLIANT MATERIALS
 5. EASILY CLEANABLE
 6. SEALED INTERIOR
 7. COLOR OPTIONS AVAILABLE
 8. CRITICAL DIMENSIONS SHOWN IN OVAL
 9. SEAL WITH #70 SPIN PATCH (NOT SHOWN)

LETTER CODES IN DRAWING NUMBER:
FOR "X" - 1 = FLAT DECK VERSION, 2 = LIP VERSION
"YYY" = COLOR DESIGNATOR

PROPRIETARY AND CONFIDENTIAL
THE INFORMATION CONTAINED IN THIS DRAWING IS THE SOLE PROPERTY OF REMCON PLASTICS INC. ANY REPRODUCTION IN PART OR AS A WHOLE WITHOUT THE WRITTEN PERMISSION OF REMCON PLASTICS INC IS PROHIBITED.

		UNLESS OTHERWISE SPECIFIED:		NAME	DATE	Remcon Plastics Inc. 208 Chestnut Street, Reading Pa, 19602	
		DIMENSIONS ARE IN INCHES TOLERANCES: FRACTIONAL: ±1/64 ANGULAR: ±1/2DEG TWO PLACE DECIMAL ±.020 in/in THREE PLACE DECIMAL ±.010 in/in		DRAWN	KM	5/28/14	TITLE: FLAT DECK, 9 LEG PALLET
		PROJECT NUMBER: 2501		CHECKED			SIZE DWG. NO. REV B 01010404800YYYY A
		MATERIAL LLDPE		ENG APPR.			
NEXT ASSY	USED ON	FINISH SB TEXTURE		COMMENTS:		SCALE: 1:10 WEIGHT: SHEET 1 OF 1	
APPLICATION		DO NOT SCALE DRAWING					

8 7 6 5 4 3 2 1