

TYPE III

TYPE III BARRICADE | PATENT PENDING

OVERVIEW

- Durable
- Easy to Assemble
- MASH TL-3 Approved



2 WARNING LIGHT POCKETS

- Anti-spin

CUSTOM GRAPHICS

- Printable area on back
- Graphics area 7.25" x 11.75"
- 1, 2, and 3 color graphics

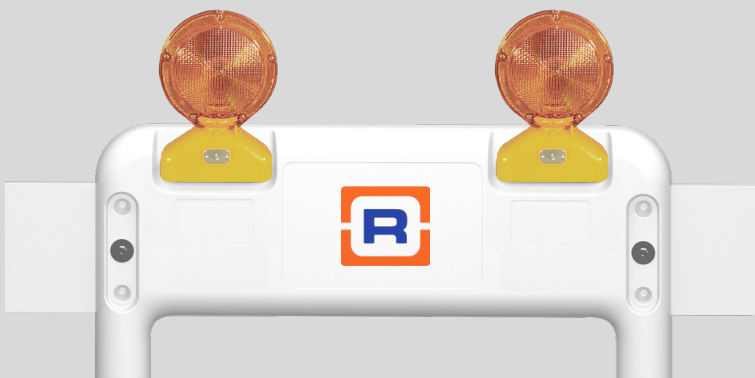

PART	OUTSIDE DIMENSIONS L" x W" x H"	WEIGHT [LBS]
UPRIGHT	38" x 3.5" x 60.5"	14
BASE	38.5" x 48" x 8.25"	11.5

EASE OF ASSEMBLY

Recesses in upright allow for a straightforward assembly process.

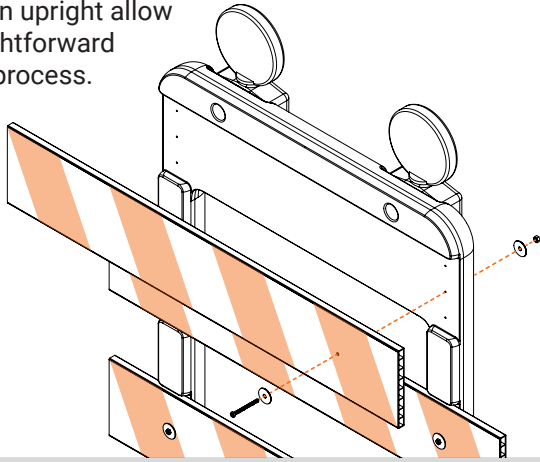

PURCHASE OPTIONS

Purchase uprights and bases together or individually as replacements.

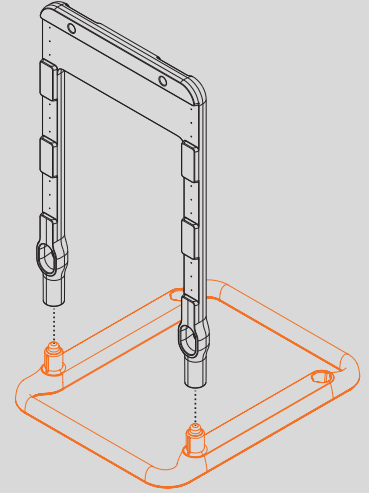

TRUCK DEPLOYMENT

Uprights and bases can be nested standing up during truck deployment.



1

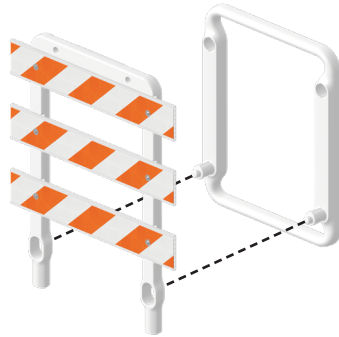

2

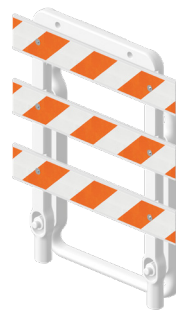

3

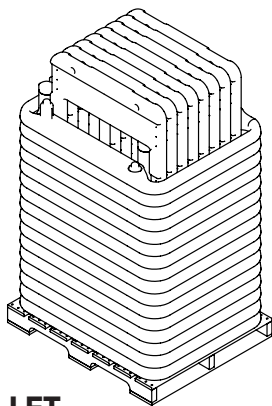
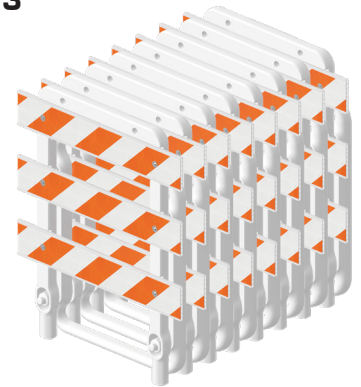

PALLET

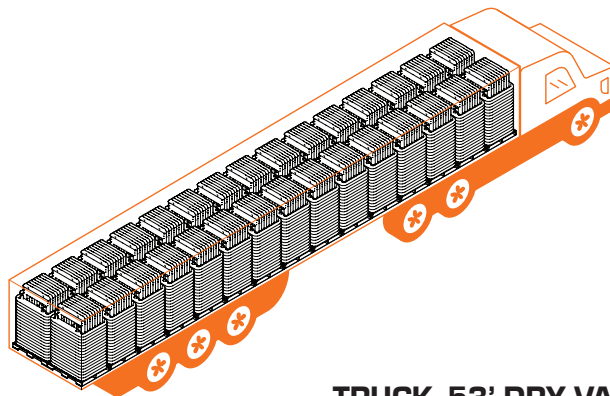

TRUCK- 53' DRY VAN

PACKING & SHIPPING

- 16 barricades per pallet
- 30 pallets per full truck
- 480 barricades per full truck