

8 7 6 5 4 3 2 1

D

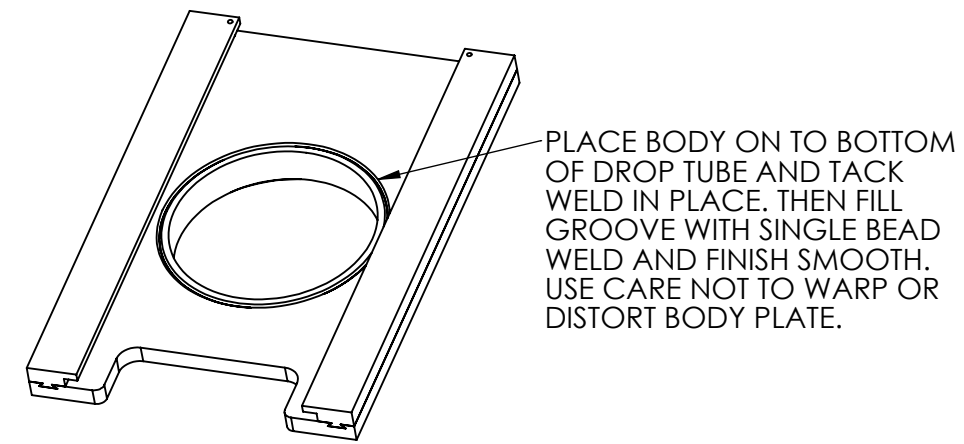
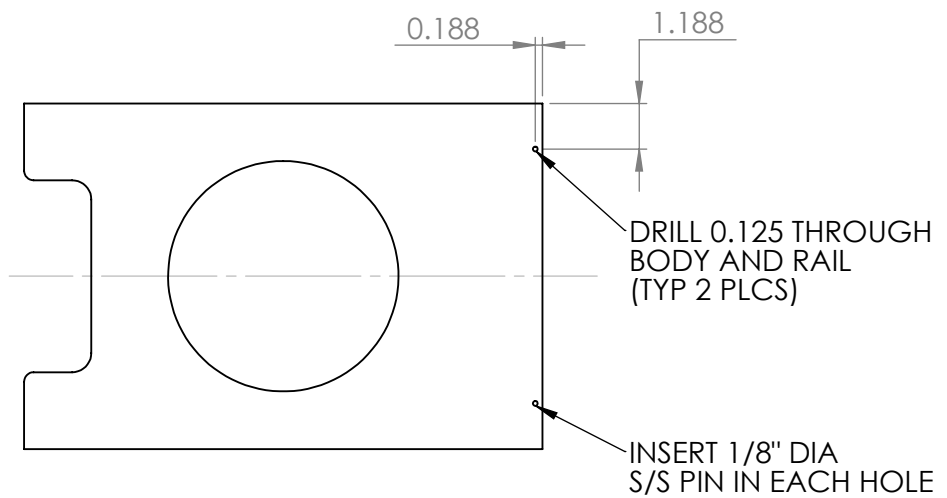
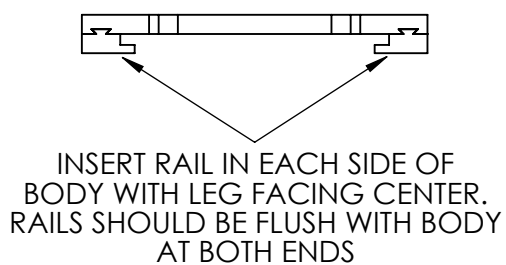

PINS SHOULD SIT 1/8" BELOW SURFACE OF BODY ON TOP AND BOTTOM. THEN PLUG WELD OVER HOLE TOP AND BOTTOM AND FINISH SMOOTH.

C

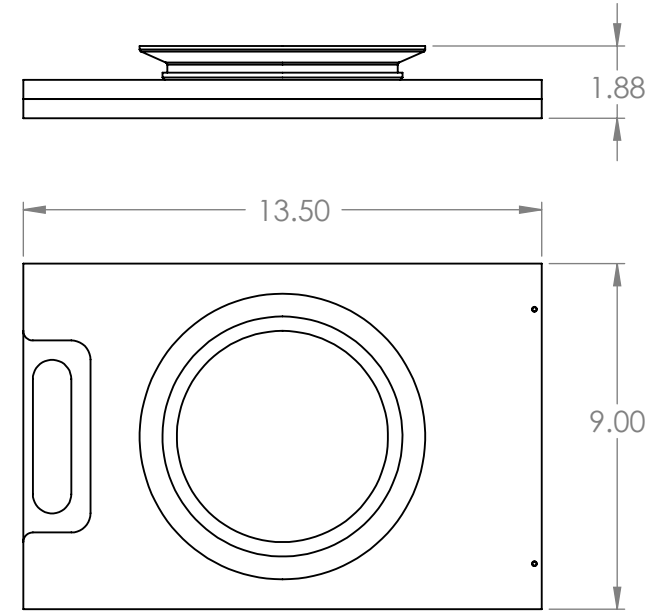
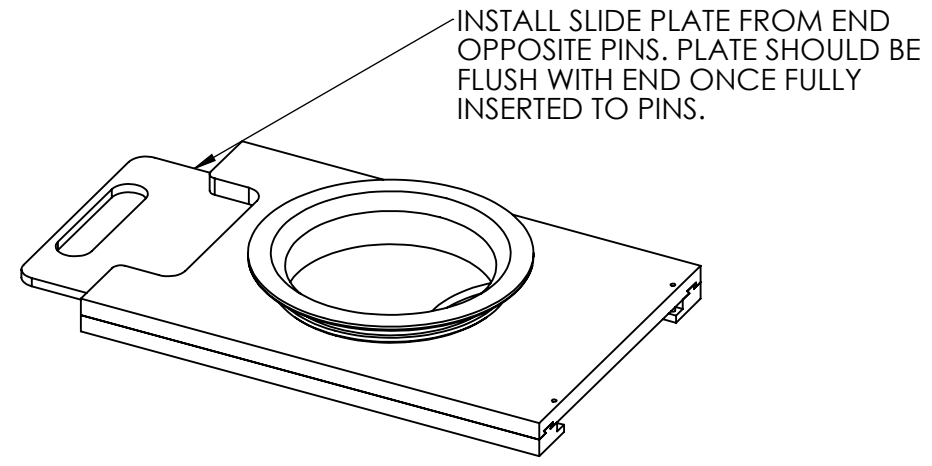
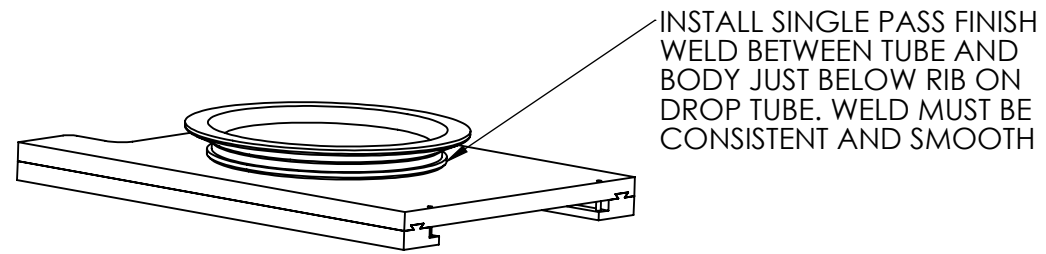

B

B

A

A

QTY.	PART NO.	DESCRIPTION
1	052700010001004	VALVE BODY
2	052700010001002	VALVE RAIL
1	052700010001005	VALVE DROP TUBE
2	051800010001001	1/8" DIA X 3/4" SS DOWEL PIN
1	052700010001003	VALVE PLATE

PROPRIETARY AND CONFIDENTIAL
 THE INFORMATION CONTAINED IN THIS DRAWING IS THE SOLE PROPERTY OF REMCON PLASTICS INC. ANY REPRODUCTION IN PART OR AS A WHOLE WITHOUT THE WRITTEN PERMISSION OF REMCON PLASTICS INC IS PROHIBITED.

		UNLESS OTHERWISE SPECIFIED:				Remcon Plastics Inc. 208 Chestnut Street, Reading Pa, 19602	
		DIMENSIONS ARE IN INCHES TOLERANCES: FRACTIONAL: N/A ANGULAR: ±1/2DEG TWO PLACE DECIMAL: ±0.013 in THREE PLACE DECIMAL: ±0.063 in		DRAWN	PFE	9/28/10	TITLE: 6 INCH PLASTIC SLIDE GATE VALVE ASSEMBLY
		PROJECT NUMBER: 2086		CHECKED	PFE	9/28/10	
		MATERIAL SEE INDIVIDUAL COMPONENT SPECS		ENG APPR.	KM	9/28/10	
		FINISH SEE INDIVIDUAL COMPONENT SPECS		COMMENTS:			SIZE
NEXT ASSY	USED ON	DO NOT SCALE DRAWING		DWG. NO.		REV	
				B 052700010001001		A	
				SCALE: 1:5		WEIGHT:	SHEET 1 OF 1

8 7 6 5 4 3 2 1