

ITEM NO.	PART NUMBER	DESCRIPTION	QTY.
1	013503341001XXX	TR-33 BULK BIN	1
2	05185000TR33000	TR-33 CASTER MOUNTING PLATE	2
3	050700044PIR42R	4 INCH RIGID CASTER	2
4	0516000TR303300	3/8-16 NYLOCK HEX NUT	20
5	0521500TR303300	3/8-16 X 1 3/4" HEX HEAD SCREW	20
6	052753800008000	3/8" PLATED FLAT WASHER	32
7	050700044PIR42S	4 INCH SWIVEL CASTER	2

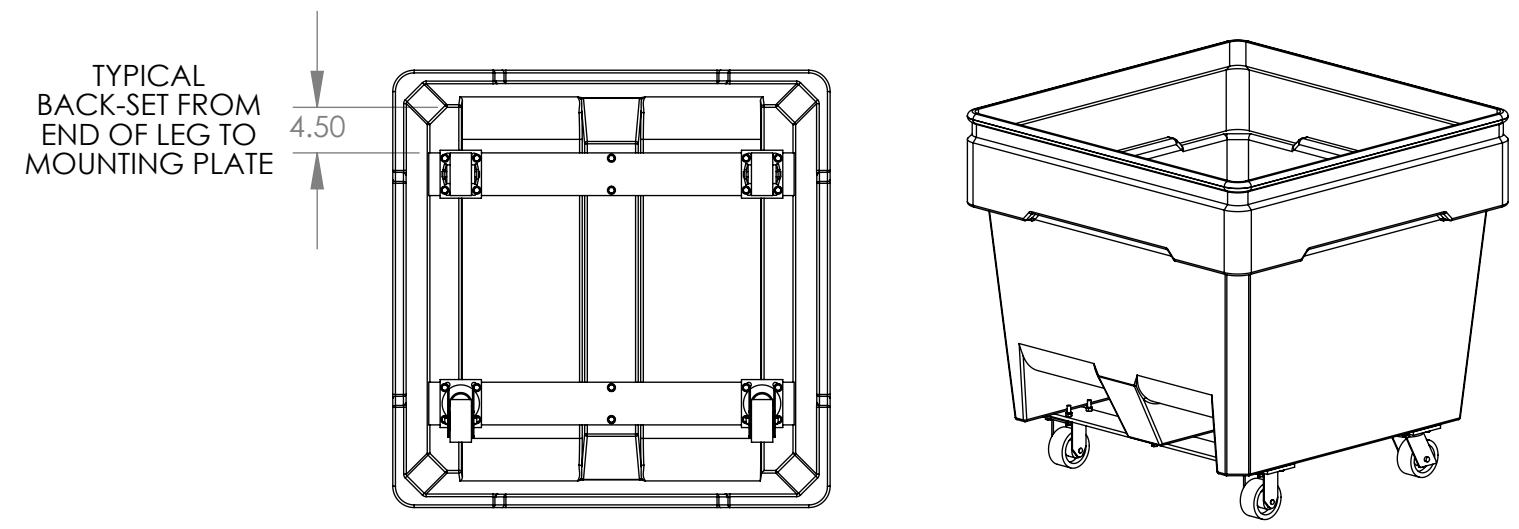

- NOTES:
1. DRAWING SHOWS ASSEMBLY DETAILS FOR TR-33 W/4 ICH CASTERS, NO BACKING PLATES
 2. MOUNTING HOLES IN BIN MAY BE DRILLED THROUGH PLATES
 3. MOUNTING HOLES IN BIN ARE 25/64" THROUGH
 4. TIGHTEN ALL HARDWARE SECURELY

PROPRIETARY AND CONFIDENTIAL
 THE INFORMATION CONTAINED IN THIS DRAWING IS THE SOLE PROPERTY OF REMCON PLASTICS INC. ANY REPRODUCTION IN PART OR AS A WHOLE WITHOUT THE WRITTEN PERMISSION OF REMCON PLASTICS INC IS PROHIBITED.

		UNLESS OTHERWISE SPECIFIED:		NAME		DATE		Remcon Plastics Inc.	
		DIMENSIONS ARE IN INCHES		DRAWN		PFE		4/18/07	
		TOLERANCES:		CHECKED		PFE		4/18/07	
		FRACTIONAL ±1/64		ENG APPR.		KM		4/18/07	
		ANGULAR: ±1/2DEG		MFG APPR.					
		TWO PLACE DECIMAL ±.020 in/in		Q.A.					
		THREE PLACE DECIMAL ±.010 in/in		COMMENTS:					
		PROJECT NUMBER: 1726						TITLE: TR-33 BULK BIN WITH 4 INCH CASTER KIT, NO BACKING PLATES ASSEMBLY	
		MATERIAL SEE B.O.M.						SIZE DWG. NO. REV	
NEXT ASSY		USED ON		FINISH SEE INDIVIDUAL PART SPECS				B 06070KITTR33040 0	
APPLICATION		DO NOT SCALE DRAWING						SCALE: 1:16 WEIGHT: N/A SHEET 1 OF 1	