

ITEM NO.	PART NUMBER	DESCRIPTION	QTY.
1	052700010001007	Body for 8 inch Fabricated Plastic Slide Gate Valve	2
2	052700010001032	Side Rail, 2 Sided, for 8 inch Fabricated Plastic Slide Gate Valve	2
3	052700010001009	Drop Tube for 8 inch Fabricated Plastic Slide Gate Valve	1
4	052700010001029	Valve Plate, 1/2" for 8 inch Fabricated Plastic Slide Gate Valve	1
5	051800010001001	Dowel Pin 1/8" Dia. x 3/4", SS #97	2

REVISIONS					
ERN/ECN	ZONE	REV.	DESCRIPTION	DATE	APPROVED
0457		A	Drawing Released	4/08/2021	BLS

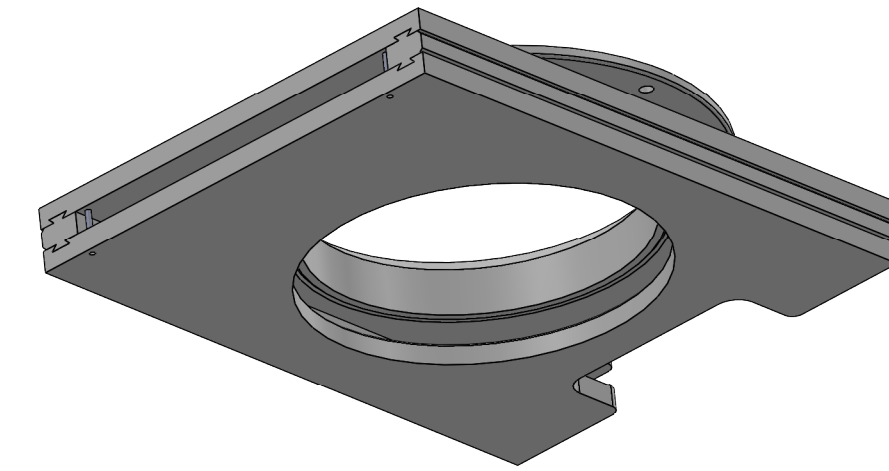

- NOTES:
- DRAWING SHOWS ASSEMBLED VALVE
  - MATERIAL IS HDPE SHEET OR PLATE, NATURAL COLOR, STRESS RELIEVED, AND FDA COMPLIANT
  - FINISH TO BE SMOOTH
  - SEE INDIVIDUAL COMPONENT DRAWINGS AND GEOMETRY FOR INFORMATION AND DIMENSIONS NOT SHOWN

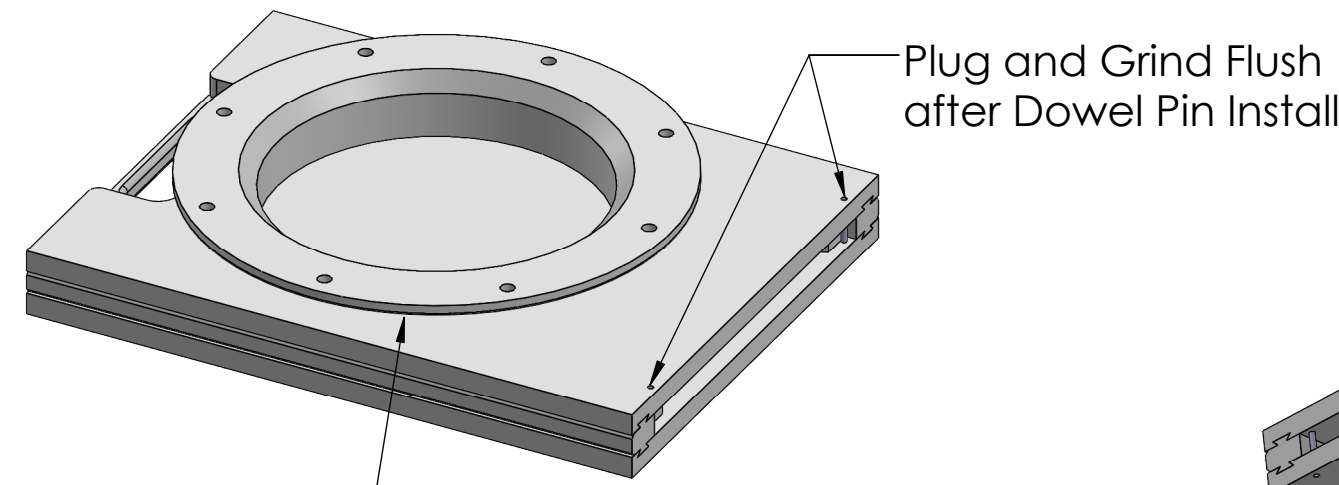
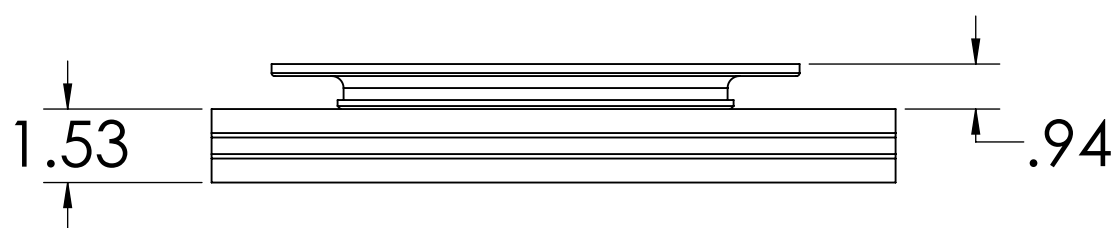
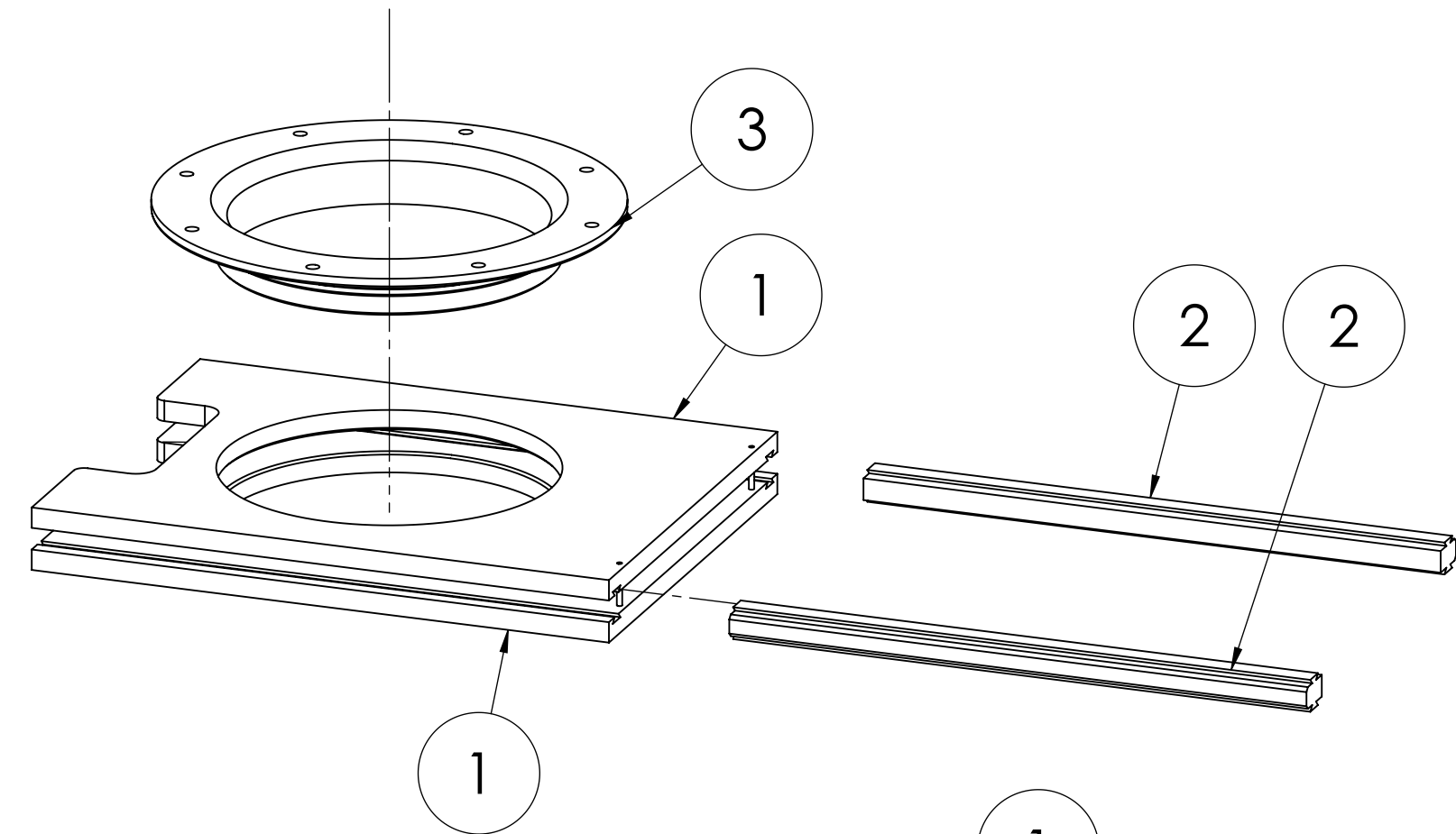
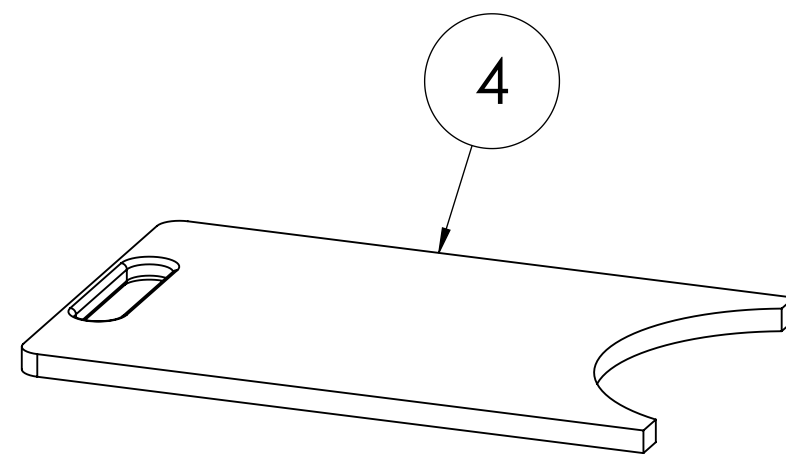
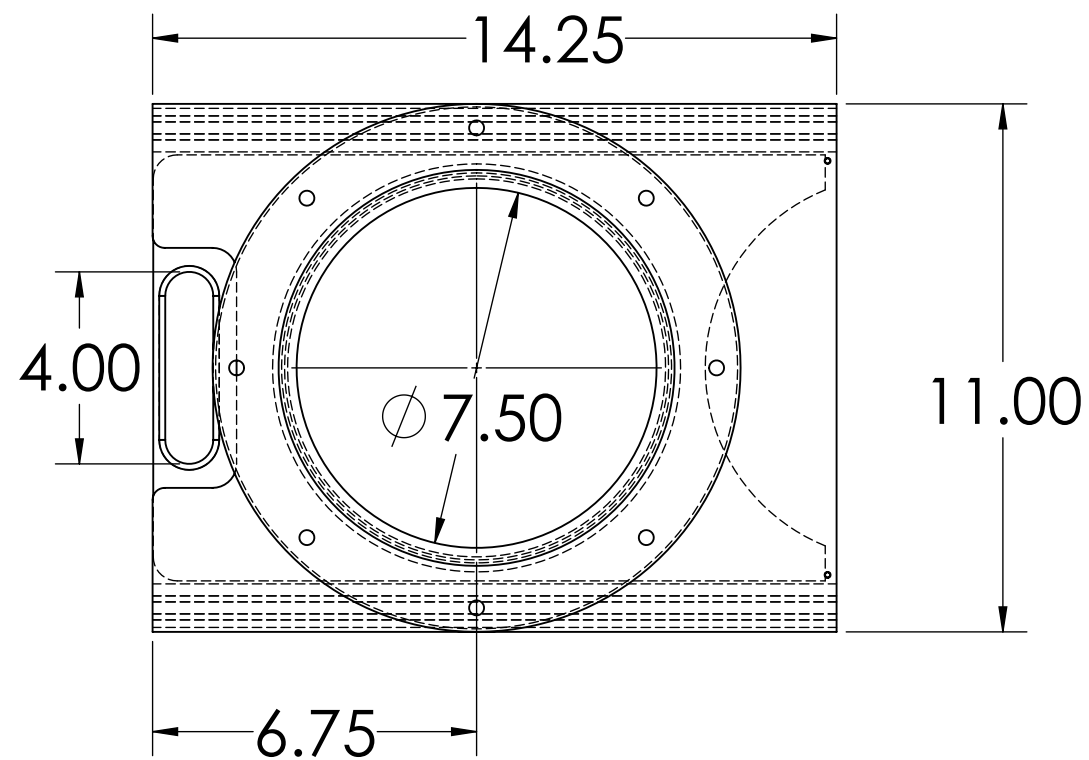

INSTALL SINGLE PASS FINISH WELD BETWEEN TUBE AND BODY JUST BELOW RIB ON DROP TUBE. WELD MUST BE CONSISTENT AND SMOOTH

INSERT RAIL IN EACH SIDE OF BODY WITH LEG FACING CENTER. RAILS SHOULD BE FLUSH WITH BODY AT BOTH ENDS

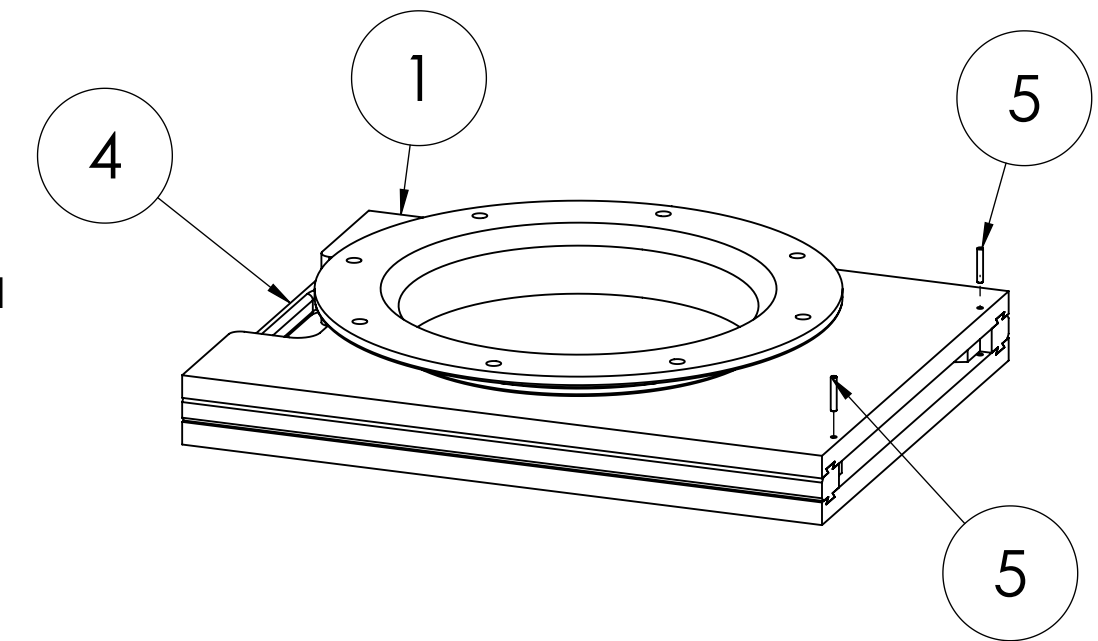

**PROPRIETARY AND CONFIDENTIAL**  
 THE INFORMATION CONTAINED IN THIS DRAWING IS THE SOLE PROPERTY OF REMCON PLASTICS, INC. ANY REPRODUCTION IN PART OR AS A WHOLE WITHOUT THE WRITTEN PERMISSION OF REMCON PLASTICS, INC IS PROHIBITED.

UNLESS OTHERWISE SPECIFIED:  
 DIMENSIONS ARE IN INCHES  
 TOLERANCES:  
 DECIMAL +/-0.010 IN/IN  
 FRACTIONS N/A  
 ANGLES +/-1°

MATERIAL  
 FINISH  
 DO NOT SCALE DRAWING

NAME  
 DATE  
 DRAWN BY: BRS 4/06/2021  
 APPROVED BY:

TITLE:  
**8 Inch, 1X Bolt on Flange, No Guide Blocks, Fabricated Slide Gate Valve**  
 WEIGHT:  
 SCALE 1:4

**REMCON** 208 Chestnut Street Reading Pa, 19602  
 PLASTICS, INCORPORATED  
 DWG. NO. 052700010001034  
 SIZE C SHEET 1 OF 1 REV A