

LOCKBANDS

1. Supplier Self Industries, Inc	2. Supplier Part Number/Customer Number REM-JD-LKS / PENDING	3. Product Description 22" 19 GA, T3, Int Ltch #5	4. Band Length 70.50 +/- .063
5. Product Composition CRCQ	6. Gauge 19 x 1.437" (.034" min)	7. Coating Type POWDER PAINT	
8. Physical Properties (Nominal) TARGET B65 ROCKWELL HARDNESS		9. Regulatory Information N/A	

10. Product Drawing

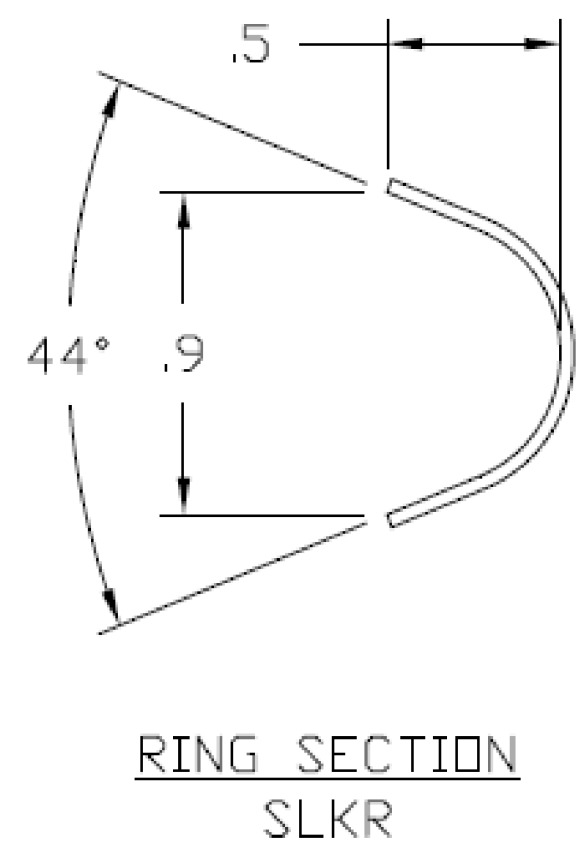
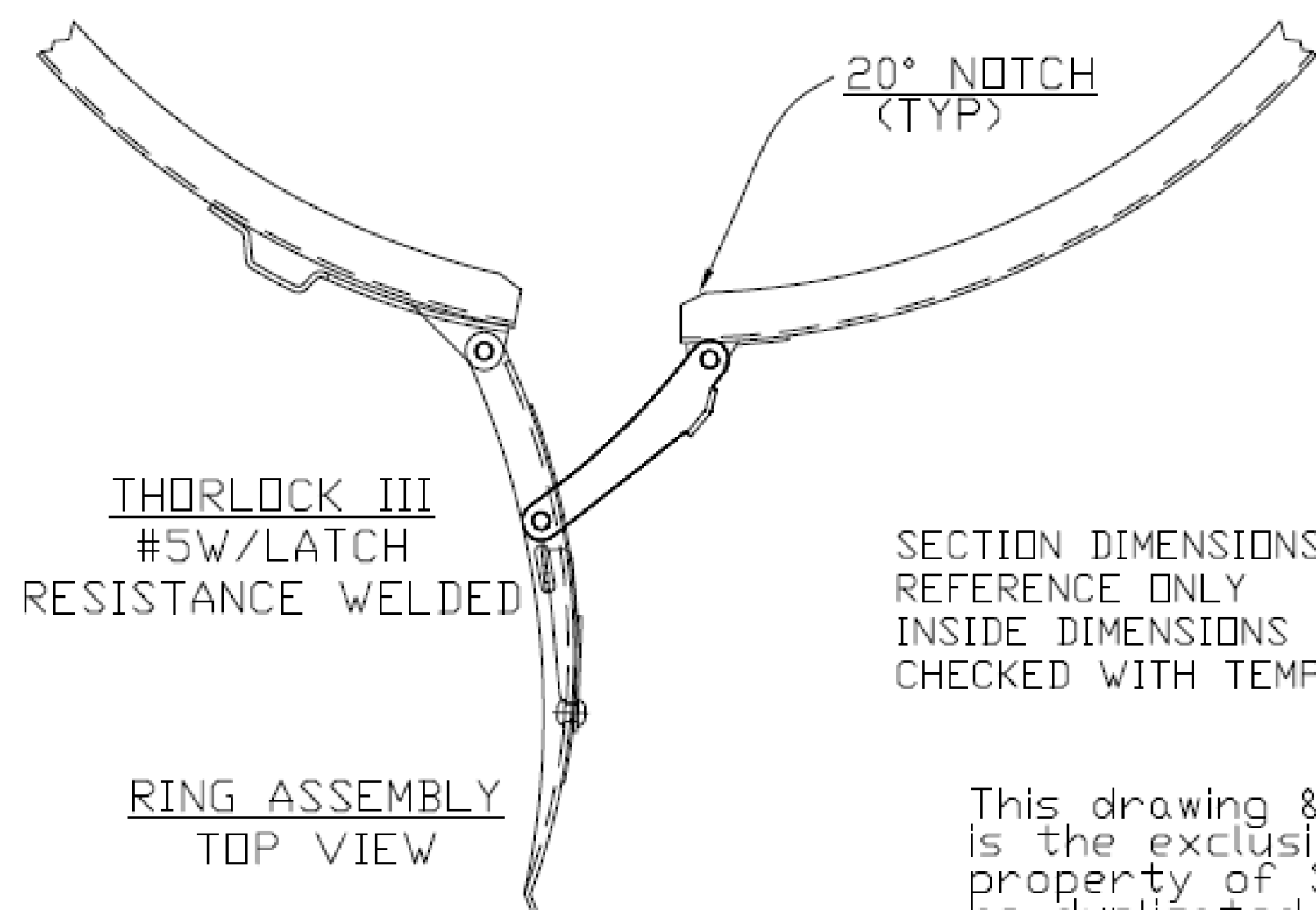

This drawing & the information contained herein is the exclusive, proprietary and confidential property of Self Industries, Inc. It shall not be duplicated, used or disclosed to others without the express written consent of Self Industries, Inc.



11. Special Requirements

S-2557 from SELFPA 3/26/2021 – APPROVED BY REMCON 4/1/2021

Revision Number A - Initial Release	Revision Date 4/1/2021	Specification Number REM-JD-LKS
---	----------------------------------	---

PROPRIETARY AND CONFIDENTIAL
THE INFORMATION CONTAINED IN THIS DRAWING IS THE SOLE PROPERTY OF REMCON PLASTICS, INC. ANY REPRODUCTION IN PART OR AS A WHOLE WITHOUT THE WRITTEN PERMISSION OF REMCON PLASTICS, INC IS PROHIBITED.

UNLESS OTHERWISE SPECIFIED:
DIMENSIONS ARE IN INCHES
TOLERANCES:
DECIMAL +/-0.010 IN/IN
FRACTIONS N/A
ANGLES +/-1°

MATERIAL

FINISH

DO NOT SCALE DRAWING

DRAWN BY:	BRS	DATE	5/3/2021
APPROVED BY:			

TITLE:	- DBH - Locking Ring 22" 19 GA, T3, Int Ltch #5
WEIGHT:	
SCALE:	1:1

REMCON 208 Chestnut Street
Reading Pa, 19602
PLASTICS, INCORPORATED
DWG. NO. 051920001001001
SIZE C SHEET 1 OF 1 REV