

ITEM NO.	PART NUMBER	DESCRIPTION	QTY.
1	059990001100113	Main Panel Chain Link Fence 69-1/2"	1
2	059990001100108	1.63 ϕ Post x 96" Tall	1
3	059990001100107	Saddle Clamp 1x5/8 x 1x5/8	4

REVISIONS					
ERN/ECN	ZONE	REV.	DESCRIPTION	DATE	APPROVED
3098		A	Release Drawing	1/18/2021	BLS

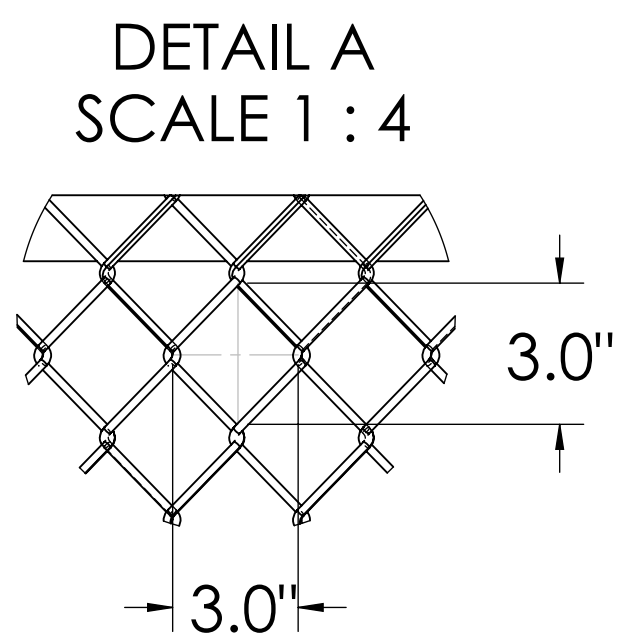
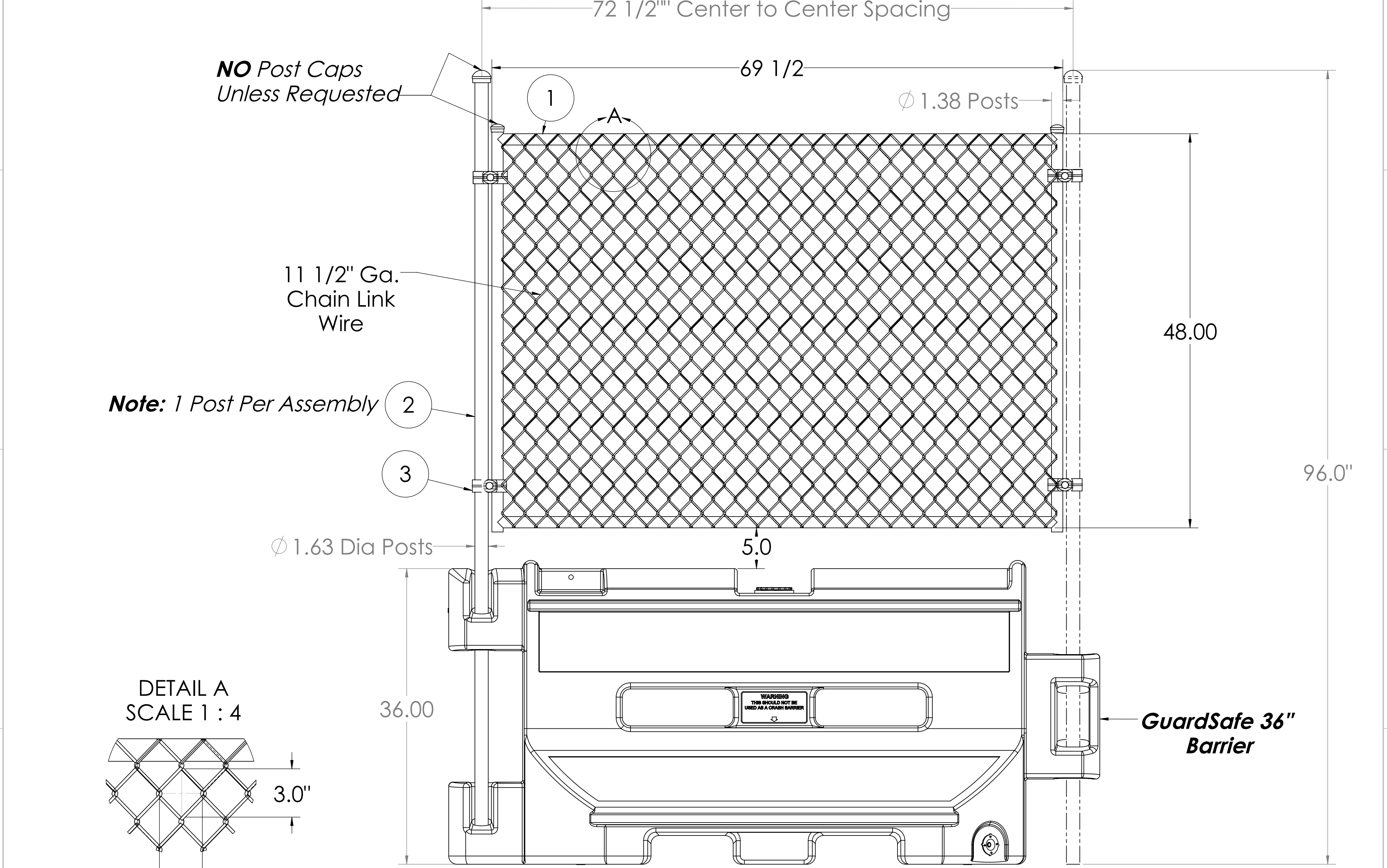

PROPRIETARY AND CONFIDENTIAL THE INFORMATION CONTAINED IN THIS DRAWING IS THE SOLE PROPERTY OF REMCON PLASTICS, INC. ANY REPRODUCTION IN PART OR AS A WHOLE WITHOUT THE WRITTEN PERMISSION OF REMCON PLASTICS, INC IS PROHIBITED.	UNLESS OTHERWISE SPECIFIED: DIMENSIONS ARE IN INCHES TOLERANCES: DECIMAL +/-0.010 IN/IN FRACTIONS N/A ANGLES +/-1°	MATERIAL	NAME	DATE	TITLE:	REMCON 208 Chestnut Street PLASTICS, INCORPORATED Reading Pa, 19602 DWG. NO. 059990001100112 SCALE 1:8 SIZE C SHEET 1 OF 1 REV A	
		FINISH	DRAWN BY:	BRS	1/18/21		Remcon - GuardSafe 36 Barrier w/ Fence Topper 72.5"
		DO NOT SCALE DRAWING	APPROVED BY:				WEIGHT: